

Digital Electronic Over Current Relays

EOCR-iFM420



R&D Technology Pty Ltd Specialised Engineering Products

Newcastle	P: +61 2 4014 9000	F: + 61 2 4014 9099
Brisbane	P: +61 7 3846 2644	F: + 61 7 3846 2346
Wollongong	P: +61 2 4285 9978	F: + 61 2 4285 9989
Gloucester	P: +61 2 6558 2986	F: + 61 2 4014 9099
Mackay	P: +61 7 4952 3833	F: + 61 2 4014 9099

E: sales@rdtechnology.com.au
website: www.rdtechnology.com.au

EOCR-i Series

Basic model :

EOCR-iFM420 Window type



General features

- Micro-Controller Unit based
- Real time processing / High precision
- Protections : Over current, Under current, Phase loss, Phase reversal, Stall, Jam, Current imbalance,
- **Thermal protection** / Inverse available up to 32Amps without external CTs.
- Auxiliary functions : Fail safe, Accumulated running hour, 3 fault records & limitation of auto-restart. Analog output
- Reinforced monitoring function : Monitoring distance up to 400M, 3 phase current display, & Trip cause indication
- Bar graph indication of a load current to the current setting.
- Available application on single and 3 phase motor
- RoHS Compliance
- normal protections are guaranteed even if PDM is disconnected.

EOCR-i Series

Basic model :

Protection functions

Protection item	Condition & Setting range	Operation time
Over current (oc)	Condition : Load current (In) exceeds setting current (Is) Setting range : 0.5~60A (Def), 0.5~32A (Inv & th)	Definite (Def) : 0.2~30s Adjust. Inverse (Inv) & Thermal (th) : 1~30 class
Under current (uc)	Condition : Load current (In) less than setting current $In \leq uc$ uc should be less than oc setting	oFF, 1~10s Adjustable
Phase loss (PL)	Condition : max imbalance is more than 85% among 3 phase current, Enable or disable : Selectable	oFF, 0.5~5s Adjustable
Reverse phase (RP)	Condition : Reversed phase sequence input on EOCR. Enable or disable : Selectable	Within 0.15s
Stall (Sc)	Condition : $In \geq$ Stall current setting (Sc). Active only in motor starting 0.5~30A : 2~8 times of oc setting ~40A : 2~6 times, ~60A : 2~4 times.	Right after D-time elapsed
Jam (JA)	Condition : $In \geq$ Jam current setting (JA). Active only in motor running 0.5~50A : 1.5~5 times of oc setting ~60A : 1.5~4 times of oc setting	0.2~5s Adjustable
Imbalance (IM)	Condition : Current imbalance \geq Setting imbalance % Setting range : 10~50% of imbalance	1~10s Adjustable

Auxiliary functions

Password	For secured setting parameters
Phase selection	For single phase / three phase motor selection
TCC selection	Available three time-current-characteristics (Definite, Inverse, Thermal inverse)
CT ratio	For the current setting more than 60A and less than 0.5A
Fail safe selection	Fail safe operation for OL trip output
Total running hour	Total accumulated running hour from the installation which cannot be modified and reset .
Reset mode	Manual / Auto / Electrical ; selectable
Trip cause memory	Store the latest 3 trip causes
Restart limitation	The maximum auto-restart number within 30 minutes in auto-reset mode.

EOCR-i Series

Basic model :

Specifications

Model			iFM420
Over current	Rated setting range (A)		Definite TCC : 0.5~60A. : use external CT higher than 60A
			Inverse & th TCC : 0.5~32A. use external CT higher than 32A
Under current	Rated setting range (A)		0.5A ~ less than oc setting
Operating time characteristics			Definite(Def) / Inverse(Inv) / Thermal(th)
Time setting	Def	D-time	0~200s
		O-time	0.2~30s
	Inv & th (cLS)		1~30 classes
Auto-reset			0.5s~20min.
Reset mode			Manual reset (H-r) / Electric reset (E-r) / Auto-reset (A-r)
Control power	Voltage		100~240VAC/DC(85% ~110%, Free voltage), 24VAC/DC(±5%)
	Frequency		50/60Hz
	Power consumption		Lower than 7VA
Output	Capacity		3A/250VAC resistive.
	Composition		1a1b : OC
Display	7 segment LED		3 phase amps, Cause of trip, Setting parameters indication.
	Bar-graph		Load factor.
Mounting			Panel mounting Flush mounting
Insulation	Between case & Circuit		Over DC500V 10M Ω
Dielectric strength	Between case & Circuit		2kV, 50/60Hz, 1 Min.
	Between contacts		1kV, 50/60Hz, 1 Min.
	Between circuit		2kV, 50/60Hz, 1 Min
Electrostatic discharge (ESD)	IEC61000-4-2		Level 3 : Air discharge : ±8KV, Contact discharge : ±6KV
Radiated disturbance	IEC61000-4-3		Level 3 : 10V/m, 80 ~ 1000MHz
Conducted disturbance	IEC61000-4-6		Level 3 : 10V,0.15~80MHz
EFT/Burst	IEC61000-4-4		Level 3 : ±2KV, 1 Min
Surge	IEC61000-4-5		Level 3 : 1.2 x 50 μ s, ±4KV (0°, 90°, 180°, 270°)
Emission	CISPR11		Class A (Conducted and radiated)
Environment	Temperature	Store	-40°C ~ +85°C
		Operation	20°C ~ +60°C
	Humidity		30~85% RH (Non-condensate)
Dimension	Window type		70W × 74.5H × 83.8D
	Bottom hole type		70W × 56.3H × 108.1D
Weight			iFM420
	Window type		420g
	Bottom hole type		460g
	Terminal type		460 + 120(PDM) = 580g
	Display (W/3M cable)		125g
Power consumption			Less than 7VA.

EOCR-i Series

Basic model :

Front face

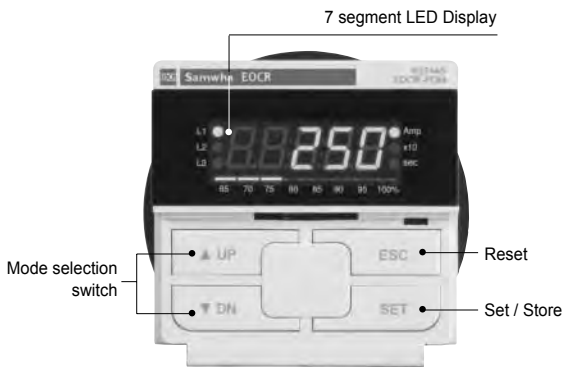

Bar graph

- it shows the load factor to OC setting value by %
- % value = (running current/setting current) * 100%
- Min scale is 65%
- if the setting value is the rated motor current, it shows the load factor of the motor.

Current Display

- Shows the highest current among three phases for OC, Stall, Jam trips.
- Shows the lowest current among three phases for UC, UB
- Shows the lost phase for PL.
- Shows the phase and the current during running.

Amp : Ampere. LED is on when a current display.

x 10 : Shows the unit changed to 10 times.

Sec : Second. LED is on when a time display.

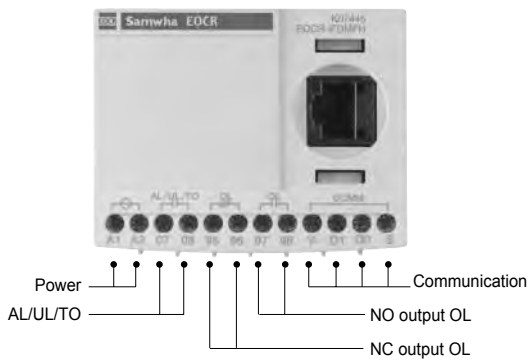

EOCR-i Series

Basic model :

3 phase digital ammeter function

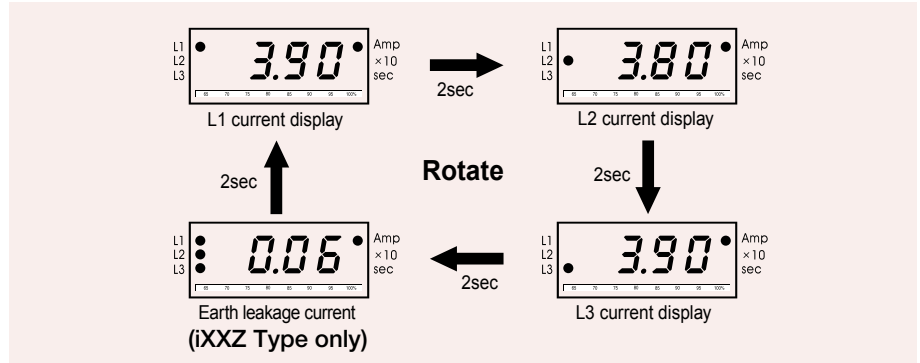

※ Blocking display rotation can be done by pressing the SET button once during running. whenever press the SET button, the each phase current displays by turns. A fixed phase current display can be done by this.
 ※ Pressing the ESC button, it returns to the Auto current display rotation mode.

Buttons and setting sequence

Button	Description
▲ UP ▼ DN	Navigate menus by pressing UP/DN button.
SET	Select a parameter to change, then the parameter starts blinking.
▲ UP ▼ DN	Modify a parameter value by pressing UP/DN button.
SET	Memorize the values in the relay by pressing SET button. blinking stops to show it's stored.
ESC	Pressing ESC button, it returns to the current display. Without pressing ESC button, it returns to the load current display in 50sec automatically.

※ Fault history check : Pressing the ESC button more than 5sec, it displays the latest fault cause and the fault current or fault phase. Continuing to press DN button, you can see the current of L1(R), L2(S), L3(T), (GR) in turn. press the DN button again to check the previous fault continually. In the latest fault display, the 100% LED of bar graph lights on and two LEDs of 95%, 100% lights on for the second fault display, three LEDs of 90%, 95%, 100% lights on for the oldest fault display. When you press the ECS button in this mode, it returns to the normal current display mode. The oldest fault record is over written when the number of fault to record exceeds three.

● Setting sequence

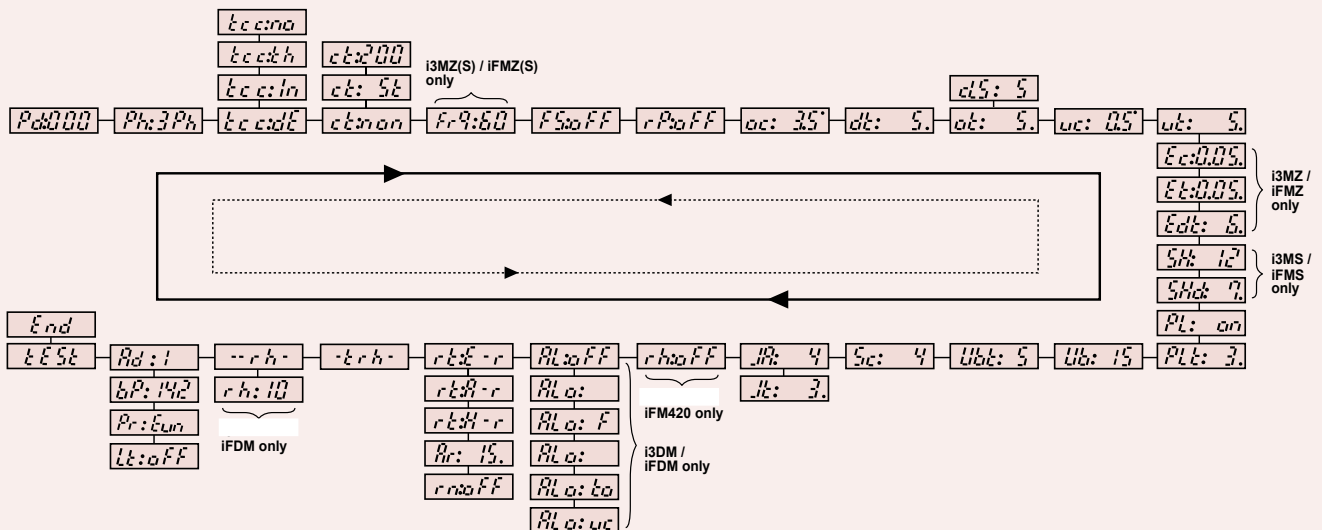

EOCR-i Series

Basic model :

Setting sequence and menu

No.	Menu	Parameter	Description	Default
1	Pass word	Pa:000	Use password other than zero for secured settings. This feature enables limitation of setting modification by unauthorized person. Zero value is used for disabling password checking.	Pa:000
2	Selection of Phase No.	Ph: 3Ph Ph: 1Ph	"Ph:3Ph" mode for a 3 phase load, "Ph:1Ph" mode for a 1 phase load should be selected. If you select the "Ph:1Ph", RP, PL and Ub functions will be disabled and not displayed in the menu mode	Ph: 3Ph
3	Operation curve	tcc:dE tcc:ln tcc:th tcc:no	Time-current characteristic(TCC) setting. "dE" is for definite TCC, "ln" is for inverse TCC, "th" is for thermal Inverse TCC. Refer to the time-current characteristic curve. If tcc=no, only overcurrent protection is disabled	tcc:dE
4	CT ratio	ct:non ct:200 ct: 2t ct:800 ct: 5t	External CT ratio setting mode. This is applied to definite TCC; higher than 60A and inverse TCC; higher than 32A. Set the primary value of the external CT. For example, 200:5 CT, setting is "ct:200". For the low-range current "ct: 2t" is for 2 pass through, "ct: 5t" is for 5 pass through. Select "ct:non" in case of no external CT and no loop.	ct:non
5 #1, #2	Frequency	Fr 9.60 Fr 9.50	Frequency setting mode. Select 50 or 60 based on the system fundamental frequency.	Fr 9.60
6	Fail safe	FS: on FS:off	Selection of fail safe(No volt release) mode for overload trip output, OL. Refer to fail-safe operation	FS:off
7	Reversed phase detection	rP: on rP:off	Enable or disable reverse phase detection	rP:off
8	Over current threshold	oc: 35	Threshold for over current protection . this value cannot be set below the under current threshold (uc).	oc: 50
9	Start delay time	dt: 5.	Motor starting delay, OC, UC, Stall, Jam, Ub are blocked during starting but PL, RP are not blocked. For "ln" TCC mode, ,the cold curve is applied before dt expires and, the hot curve is applied after dt expires.	dt: 5.
10	Over current duration (Trip delay time / Trip class)	ot: 5.	(tcc:dE) ; the fault(over current) duration of definite overcurrent protection. (tcc:ln) ; the trip class for inverse overcurrent protection(refer to TCC curve) (tcc:th) ; the thermal overload protection based on the thermal image by load current (refer to TCC curve).	ot: 5.
11	Under current threshold	uc: 0.5	Threshold for under current protection. The setting should be higher than no-load current of a motor. The current value cannot be set higher than OC.	uc:off
12	Under current duration (Trip delay time)	ut: 5.	Fault (under current) duration for the under current Operation. If the setting of "oFF" in the "uc" mode is selected, this menu is not displayed	ut: 5.
13 #1	Earth fault (Ground fault) threshold	Ee:0.06	Threshold for earth fault protection. The capacitance leakage current of the motor and cable should be taken into account for the setting. The threshold value corresponds to the primary current of ZCT	Ee: 0.5
14 #1	Earth fault trip delay time	Et:0.05	Earth fault duration (Trip delay time) TCC is definite characteristic	Et:1 .
15 #1	EF starting delay	Ede: 6.	Blocking time of Earth Fault detection during motor starting. OFF, 1~30s adjustable This timer is only active during motor starting.	Ede: 0.
16 #2	Short circuit current threshold	SH: 12	Threshold for short circuit detection. This value is the multiples of the over current threshold (oc). The SC fault duration is fixed to 0.05 second.	SH: 10

EOCR-i Series

Basic model :

Setting sequence and menu

No.	Menu	Parameter	Description	Default
17 #2	SC starting delay	SHd: 7.	Blocking time of short circuit detection during motor starting. This timer is only active during motor starting.	SHd: 0.
18	Phase loss	PL: on PL:off	Enable or disable phase loss(Single phasing) detection. If the "Ph:1Ph" is selected, this menu is not displayed.	PL: on
19	Phase loss time	PLt: 3.	Fault duration for phase loss operation. The setting range is 0.5~5 sec. if "PL:off" is selected, this menu is not displayed	PLt: 3.
20	Imbalance threshold	Ub: 15	Threshold for current imbalance operation. To disable the function, set to "oFF", the setting range is 10~50%. Imbalance factor (%) = $(I_{\max_phase} - I_{\min_phase}) / I_{\max_phase} \times 100\%$	Ub: 15
21	Imbalance fault duration	Ubt: 5	Imbalance fault duration (trip delay time) for current imbalance operation. The setting range is 1~10 seconds.	Ubt: 5
22	Stall threshold	Sc: 4	Threshold for locked rotor detection during motor starting. The value is the multiples of the over current threshold(oc). If the locked rotor condition is detected, the trip relay operates in 0.5s after the "dt" expires. If dt=0, this function is disabled and not displayed in the menu. Setting range : oc=0.4~30A:2~8times, oc < 40A:2~6times, otherwise (oc<60A) : 2~4times, (with Ext. CT : 2~8times)	Sc: 4
23	Jam threshold	Jr: 4	Threshold for locked rotor detection during motor running. The value is the multiples of the over current threshold (oc). Setting : oc=0.4~50A : 1.5~5times, otherwise (oc<60A) : 4times, (with Ext. CT : 15~5times)	Jr: 4
24	Jam fault duration	Jt: 3.	Jam fault duration (trip delay time) Setting : 0.2~10 sec	Jt: 3.
25 #3	420 Output range	r5: 5.0*	Reference value for max analog output (20mA) If the load current is equal or greater than this value, analog output is fixed to 20mA	r5: 5.0*
26 #4	Alert	AL: 85 AL:off	Threshold of Alert output, set by % of the over current threshold (oc). If the load current is higher than this value, alert output(07-08 contact) is energized according to the setting of "ALo: XX".	AL:off
		ALo: A	If the load current is detected, alert output(07-08 contact) is energized. The alert threshold is no meaning for this operation. Refer to the alert operation pattern.	
		ALo: F	If the load current is higher than the alert threshold, alert output(07-08 contact) repeats open for 1s and close for 1s (flickering), The flickering starts from the motor starting. Refer to the alert operation pattern.	
		ALo: H	If the load current is higher than the alert threshold, alert output(07-08 contact) is closed (holding) and remains closed until the load current decrease under the alert threshold. The alert output is blocked during motor starting. Refer to the alert operation pattern.	
		ALo:ta	If the accumulated running hour is more than the running hour threshold, the alert output repeats close for 1s and open for 1s.	
		ALo:uc	The alert output is used only for under current protection. If this mode is selected, a trip by an under current fault is signaled through alert output (07-08), instead of overload trip output(95-96 or 97-98).	

EOCR-i Series

Basic model :

Setting sequence and menu

No.	Menu	Parameter	Description	Default
27	Reset		Fault reset (Electrical reset) by a power cycle or by pressing the ESC button.	
			Fault reset (Hand reset) by only pressing the ESC button.	
		 	Fault reset (Auto Reset) by a auto-reset timer, Setting range of the timer : 0.5sec~20min. Also the fault can be reset by power cycle or by ESC button. The relay cannot be reset automatically when the relay is tripped by Phase Reversal(rP), Phase Loss(PL), Stall(Sc) and Jam(JA)	
28	Restart limitation		The maximum auto-restart number during 30 minutes in auto-reset mode. The auto-restart counter (count) is stored in the non-volatile memory and is cleared by pressing ESC button when the counter(count) reaches the limitation. To disable limitation, select "oFF". Setting range : oFF~5 times.	
29	Total running hour	 ↔	In this menu, toggle display, "-trh-" and the accumulated (time) value, is activated (?) The accumulation starts from the installation and the user cannot clear the accumulated value. This display unit is 1 hour.	read only
30	Running hour	 ↔	In this menu, toggle display, "--rh-" and the accumulated value, is activated (?) The user can clear the accumulated value by selecting the running hour threshold to "rh:oFF". This display unit is 0.1 hour (6 minutes). By selecting "ALo:to", the user can get the alert signal through alert output (07-08) when the accumulated value is more than the running hour threshold.	read only
31	Running hour threshold		Threshold for alert output when the user selects "ALo:to". The unit is 10 hours and this menu is not displayed when the motor is starting or running. Setting range : 10~9990 hours, oFF	

33	Test trip		When this menu activated, OL trip signal and enabled short or EF trip signal is generated when (3s+ot) expires. The display shows "End" when the test is done. By pressing ESC, returns to the load current display mode. This menu is not displayed when the motor is starting or running. Before (3s+ot) expires, pressing ESC or motor starting or running blocks the test trip and return to the load current display. No parameter	No parameter
34	End		This shows the end of test trip. Test result is stored in the fault record.	No parameter

※ #1 => These are applied to i3MZ & iFMZ only.

#2 => These are applied to i3MS & iFMS only.

#3 => This is applied to i3M420 & iFM420 only.

#4 => This is applied to i3DM & iFDM only.

※ Menus from password to reversed phase detection are not displayed during the motor running.

EOCR-i Series

Basic model :

Fail-safe operation

Fail-Safe	A1-A2 not powered	A1-A2 powered and under normal operation	A1-A2 powered and Tripped
ON	95 96 Close	95 96 Open	95 96 Close
	97 98 Open	97 98 Close	97 98 Open
OFF	95 96 Close	95 96 Close	95 96 Open
	97 98 Open	97 98 Open	97 98 Close

Trip cause indication and fault records

3 fault records including the trip cause and 3phase currents are stored in a non-volatile memory.

When the motor is running or stopped, trip cause can be navigated by pressing ESC button over 5seconds

Trip indication					
Trip			Indication after trip with UP/ DN button pressing		
Trip cause	Indication	Contents of indication	L1 LED on	L2 LED on	L3 LED on
Over current		OC Trip caused by r(L1)-phase current			
Phase loss		Phase Loss caused by r(L1)-phase lost			
Reversed phase		Phase reversal trip			
Stall		Stall trip during motor starting caused by s(L2)-phase current			
Jam		Jam trip during motor running caused by t(L3)-phase current			
Imbalance		Imbalance trip caused by t(L3)-phase current			
Under current		Under current trip caused by s(L2)-phase current			

Limitation of auto-restart		In 30minutes, the number of auto-restart by auto-reset exceeds the setting	For emergency restart, manual reset by pressing ESC clears the restart counter to zero.
----------------------------	--	--	---

EOCR-i Series

Basic model :

Time-current characteristic curve

Inverse characteristic

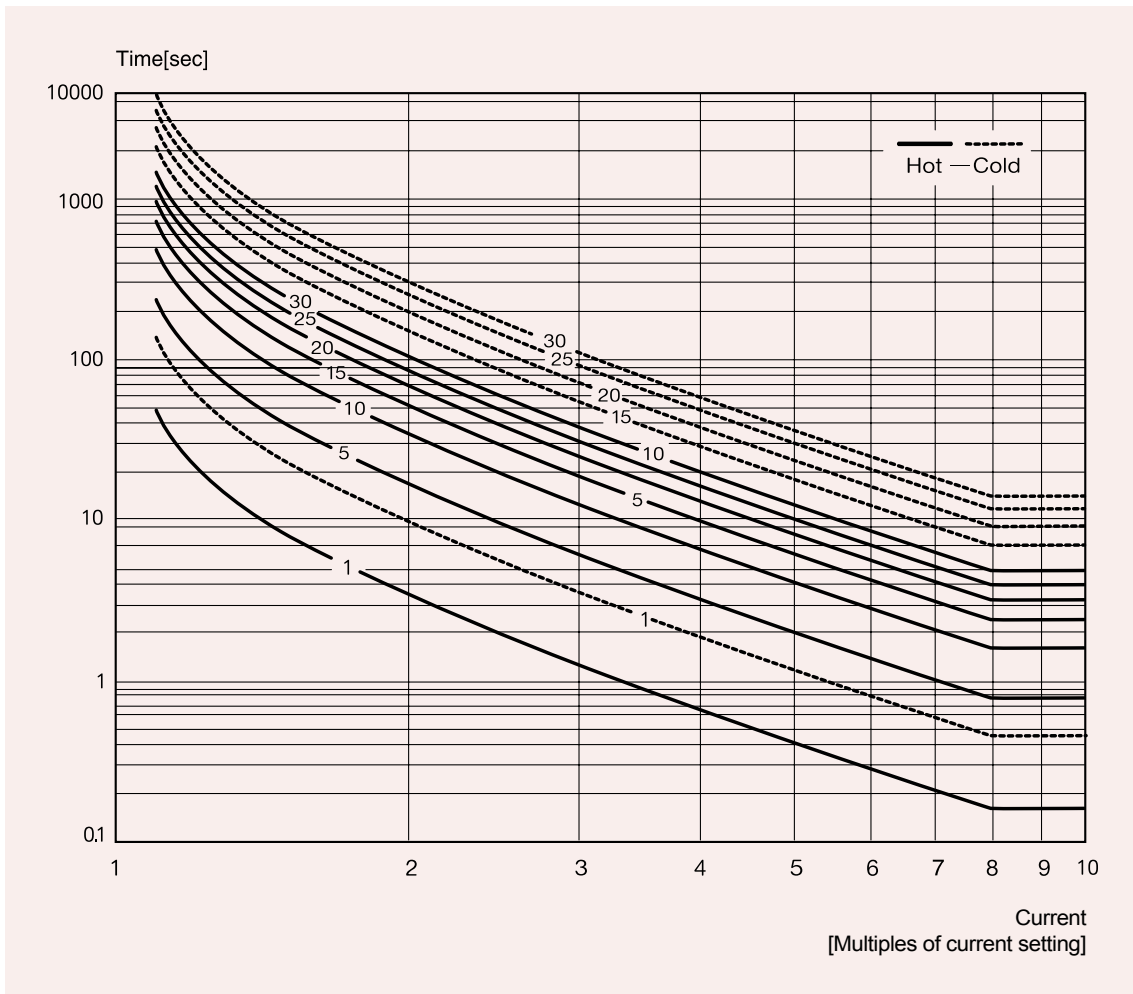

Definite characteristic

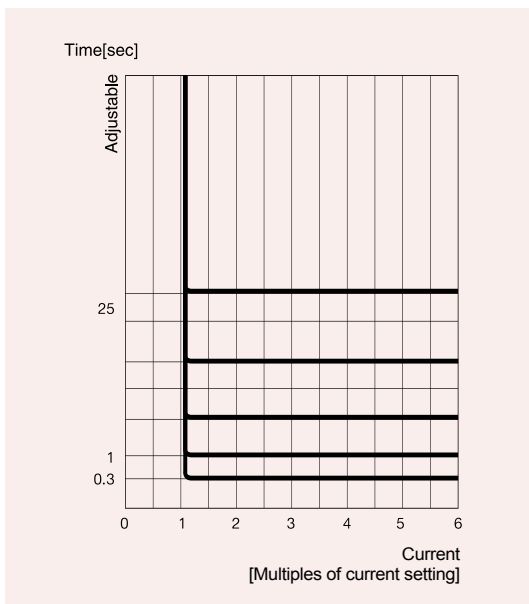

Thermal inverse characteristic

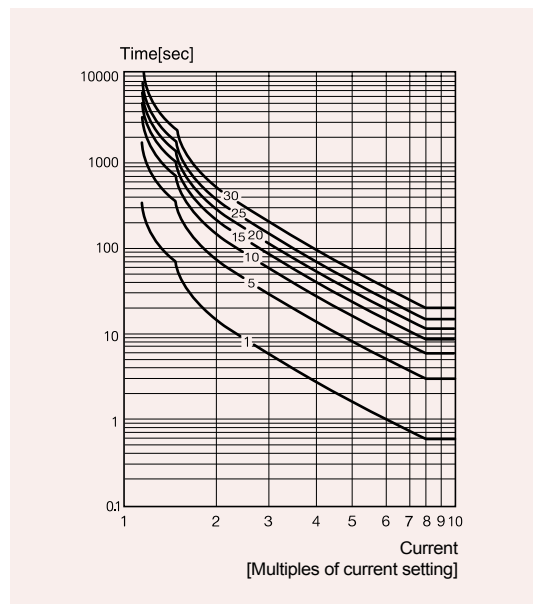

EOCR-i Series

Basic model :

Current setting range

Setting range	Number of pass through the CT hole	External CT ratio	CT Setting	Remark
0.5 ~ 60A	1	No CT combination	ct:n0n	
0.25 ~ 3A	2	No CT combination	ct:2t	
0.1 ~ 1.2A	5	No CT combination	ct:5t	
0.5 ~ 32A	1	No CT combination	ct:n0n	Inverse TCC or thermal Inverse TCC
0.5 ~ 60A	1	No CT combination	ct:n0n	Definite TCC
10 ~ 100A	1	100 : 5	ct:100	Definite or inverse (th)
20 ~ 200A	1	200 : 5	ct:200	Definite or inverse (th)
30 ~ 300A	1	300 : 5	ct:300	Definite or inverse (th)
40 ~ 400A	1	400 : 5	ct:400	Definite or inverse (th)
50 ~ 500A	1	500 : 5	ct:500	Definite or inverse (th)
60 ~ 600A	1	600 : 5	ct:600	Definite or inverse (th)
70 ~ 700A	1	700 : 5	ct:700	Definite or inverse (th)
80 ~ 800A	1	800 : 5	ct:800	Definite or inverse (th)

EOCR-i Series

Basic model :

Typical wiring schematic

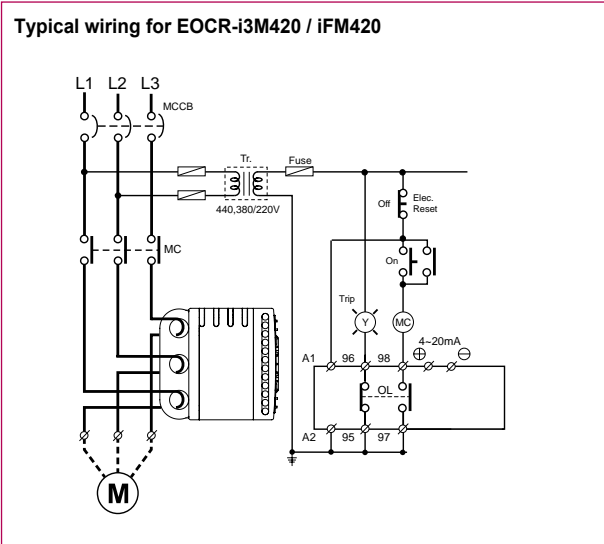

EOCR-i Series

Basic Model :

Control terminals

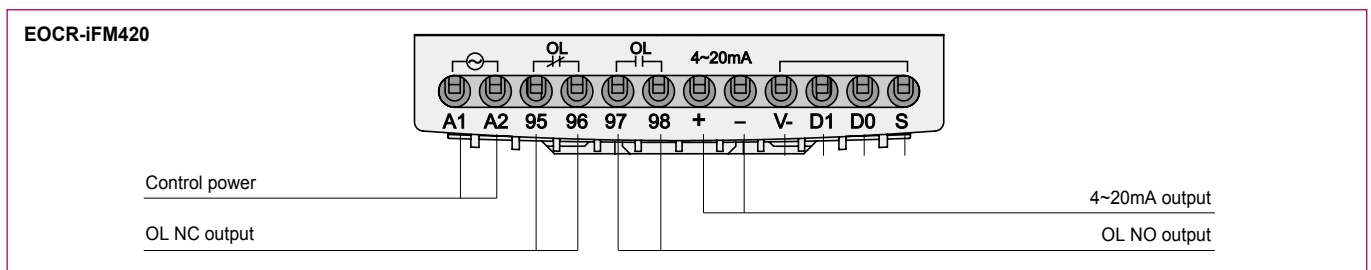



EOCR-i Series

Basic model :

Dimension of iFX

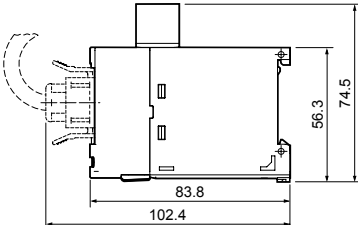
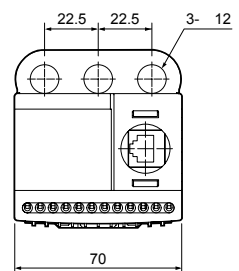
Window type
EOCR-iFM420



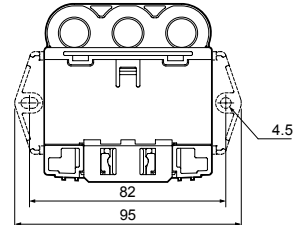

PANEL & DIN RAIL TYPE

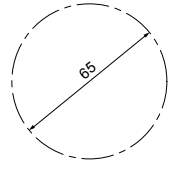
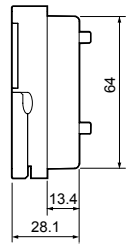
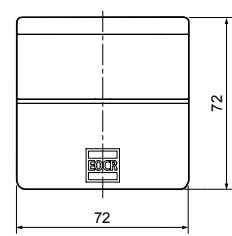

MOUNTING HOLE SIZE

Display
EOCR-PDM





MOUNTING HOLE SIZE

EOCR-i Series

Basic model :

Ordering

<p>Display</p> 	<p>EOCR-PDMQ</p>																			
<p>Cable connector</p> 	<p>CABLE - RJ45 - 001</p> <div style="display: flex; justify-content: center; gap: 20px;"> ① ② </div> <table border="1" style="width: 100%; border-collapse: collapse;"> <thead> <tr> <th style="width: 5%;">①</th> <th style="width: 40%;">Connector type</th> <th colspan="2" style="width: 55%;">RJ45</th> </tr> </thead> <tbody> <tr> <td rowspan="6" style="text-align: center; vertical-align: middle;">②</td> <td rowspan="6" style="text-align: center; vertical-align: middle;">Cable length</td> <td style="text-align: center;">00H</td> <td style="text-align: center;">0.5 m</td> </tr> <tr> <td style="text-align: center;">001</td> <td style="text-align: center;">1 m</td> </tr> <tr> <td style="text-align: center;">01H</td> <td style="text-align: center;">1.5 m</td> </tr> <tr> <td style="text-align: center;">002</td> <td style="text-align: center;">2 m</td> </tr> <tr> <td style="text-align: center;">003</td> <td style="text-align: center;">3 m</td> </tr> <tr> <td style="text-align: center;">Others</td> <td style="text-align: center;">Custom made</td> </tr> </tbody> </table>	①	Connector type	RJ45		②	Cable length	00H	0.5 m	001	1 m	01H	1.5 m	002	2 m	003	3 m	Others	Custom made	
①	Connector type	RJ45																		
②	Cable length	00H	0.5 m																	
		001	1 m																	
		01H	1.5 m																	
		002	2 m																	
		003	3 m																	
		Others	Custom made																	
<p>SR-CT</p> 	<p>SR-3CT - 100</p> <div style="display: flex; justify-content: center; gap: 20px;"> ① </div> <table border="1" style="width: 100%; border-collapse: collapse;"> <thead> <tr> <th style="width: 5%;">①</th> <th style="width: 30%;">CT ratio</th> <th style="width: 15%;">S1</th> <th style="width: 10%;">100</th> <th style="width: 40%;">100:5</th> </tr> </thead> <tbody> <tr> <td rowspan="5" style="text-align: center; vertical-align: middle;">①</td> <td rowspan="5" style="text-align: center; vertical-align: middle;">CT ratio</td> <td style="text-align: center;">SH</td> <td style="text-align: center;">150</td> <td style="text-align: center;">150:5</td> </tr> <tr> <td style="text-align: center;">S2</td> <td style="text-align: center;">200</td> <td style="text-align: center;">200:5</td> </tr> <tr> <td style="text-align: center;">S3</td> <td style="text-align: center;">300</td> <td style="text-align: center;">300:5</td> </tr> <tr> <td style="text-align: center;">S4</td> <td style="text-align: center;">400</td> <td style="text-align: center;">400:5</td> </tr> </tbody> </table>	①	CT ratio	S1	100	100:5	①	CT ratio	SH	150	150:5	S2	200	200:5	S3	300	300:5	S4	400	400:5
①	CT ratio	S1	100	100:5																
①	CT ratio	SH	150	150:5																
		S2	200	200:5																
		S3	300	300:5																
		S4	400	400:5																

Technical information

Option-1. Looping (Protect smaller current by looping option)

Some motor size may require one-third or one-fourth of particular EOCR current range. These installations can be accommodated by looping the motor wire 2 or 3 times through the integral current transformers of the EOCR. This reduces the number and type of relays inventoried for spare purposes. Each additional loop will increase the current measured as indicated by the following chart.

	Current setting range (A)	No. of passing (#)	No. of loops (#)
05 Type	0.5 ~ 6	1	0 ...
	0.25 ~ 3	2	1 ...
Looping Option	0.17 ~ 2	3	2
	0.12 ~ 1.5	4	3
	0.10 ~ 1.2	5	4
	▼	▼	▼



Option-2. External current transformer option (Ext. CT option protect bigger current)

Ordering option - 05 type of each model fitted to an external current transformer can achieve higher ampere ranges.
(EOCR-3DM/3MZ/3M420/FDM/FMZ/FM420)

	DIP SW setting	Current setting range (A)	Current ratio of Ext. CT
05 type	05	0.5 ~ 10	NIL
60 type	60	5.0 ~ 60	NIL
	05	10 ~ 120	100 : 5
Ext. CT option	05	15 ~ 180	150 : 5
	05	20 ~ 240	200 : 5
	05	30 ~ 360	300 : 5
	▼	▼	▼



EOCR type table for 3 phase motor

EOCR type and CT	Current setting range (Adjustable) [A]	Capacity of 3 phase motor				Motor current [A]			Cable size IEC [mm ²]		
		AC220 [V]		AC380/440 [V]		AC220V	AC380V	AC440V	AC220V	AC380V	AC440V
		kW	HP	kW	HP						
05	0.5~10	0.75	1	1.5	2	4.8	4.2	3.6	4	4	4
60	5~60	11	15	22	30	48	49	42	16	25	25
100:5	10~120	22	30	37	50	93	84	73	50	50	50
150:5	15~180	30	40	55	75	125	121	105	70	70	70
200:5	20~240	37	50	75	100	160	163	141	95	120	120
300:5	30~360	75	100	132	175	310	263	227	300	240	240
400:5	40~480	-	-	190	250	440	376	325	-	400	400
500:5	50~600	-	-	220	300	572	424	390	-	-	400

EOCR setting platform / Motor running current

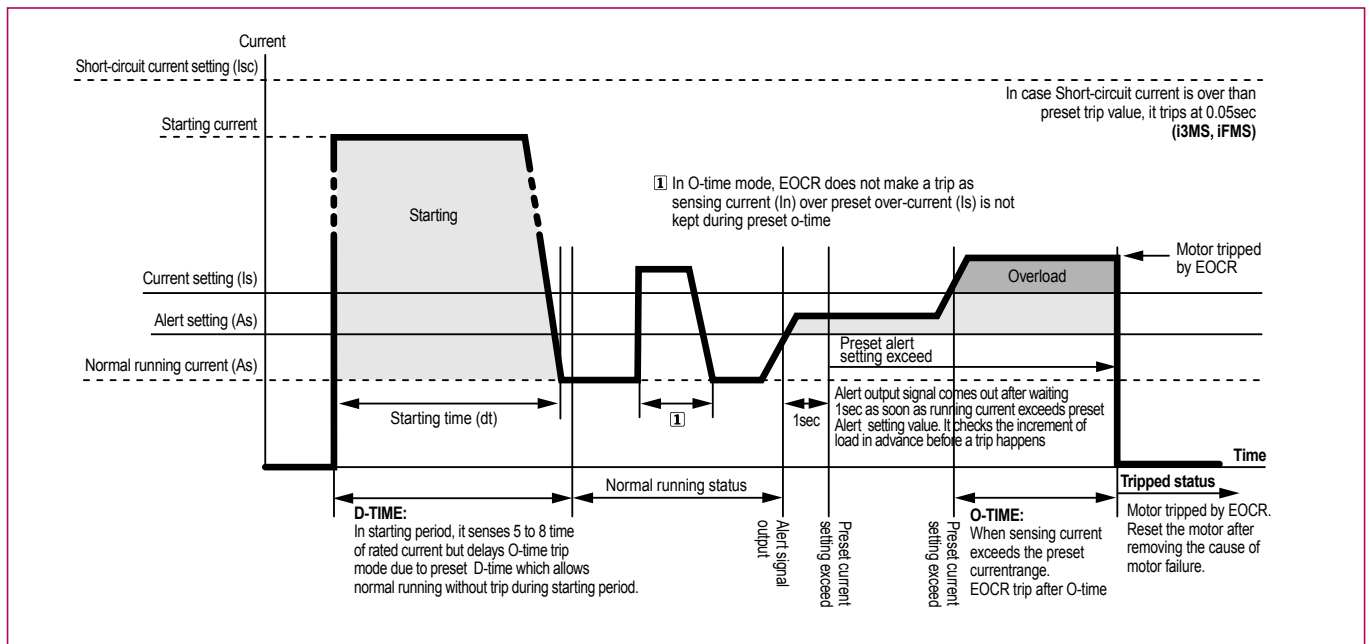

Over current and time setting tips.

■ Setting tips in definite TCC mode

- 1. Over current threshold (OC) :** Set the OC at the rating current of a motor. To protect machine together, it is recommended to set at 110~120% of the actual normal operating current.
- 2. Starting delay time (D-time) :** Set an expected start-up time to reach the normal speed of load. If you do not know it, set to 15sec at first and start-up the motor to measure the time to reach the normal operation speed by monitoring the displayed current and then change the time into 2 sec longer than the time measured. For a Y-D start, it's better to set time longer than the preset time of the timer by 2sec minimum normally.
- 3. Operation time (O-time) :** Set the trip delay time which activates and counts down under a fault condition.

■ Setting tips in inverse or thermal inverse TCC mode

- 1. Over current (OC) :** Set the OC at the rating current of a motor.
- 2. Starting delay time (D-time) :** Usually, set D-time to zero. With zero D-time, the cold curve is applied before the load current cross down the OC, and then the hot curve is applied.
If the start-up time is long and fast trip is required during motor running, set D-time to start-up time or longer. In this case, over current protection is blocked during the start-up, and the hot curve is applied when D-time expires.
Since thermal inverse has no relation with D-time, set D-time to zero when the thermal inverse is selected.
- 3. Operation time (O-time) :** It has 30 curves of 1~30 which conforms to the IEC947-4-1 standard.
The class value approximately equals to the time to trip under 550% of overload by the cold curve characteristic.



EOCR Setting Guide

EOCR Setting Guide

This is a setting guide and advice for user's reference only .

Conditions to be checked for the normal operation of EOCR .

1. Check the status of correct settings by pressing the UP/DN button in sequence.
2. When you enter the **tESt** menu and wait for 3 sec, it starts countdown during the O-time **ot: 5** setting. and display **End** with a trip to the output . This means EOCR is operating well.
3. Check all the sequence wiring if it is safe and correct .
4. After completion of the motor starting, check if the current display is fine, When the %LED in the bar graph doesn't show, it needs to check if the operation current is too lower than the Oc setting value by 65% and on the contrary, the %LED shows 100% (red LED lights on), It is advised to check the Oc setting if the re-adjustment is necessary.
5. If the motor starting isn't completed but EOCR operates, refer to the Troubleshooting guide first and contact customer care center if the trouble isn't cleared.

Basic model (3DM / FDM)

pd:000 Password input is necessary to change the setting value of EOCR, if a password is memorized except 000. If the password is set to 000, no password input is necessary in "000" to enter the setting change mode. Please take caution not to forget the password.No password function is provided in 3DM2/FDM2, 3M22/FM22.

ph:3Ph The default setting is a 3phase motor. The setting change to **ph:1Ph** is necessary for 1 phase motor.

tcc:dE Time current characteristic (TCC). the default setting is tcc : dE (definite TCC).

ct:nOn The default setting is "non", setting value is the primary current with an external CT combination in this mode. (Ex: in case of 200; 5, the setting is 200)

FS: on If the control power or EOCR itself has a problem, the motor stops with the output relay trip in the "FS: on" mode. The default setting is. **FS:oFF**

rP: on For the application which motor rotation direction is important , "rP: on" should be set . "rP:oFF" setting doesn't make a problem after completion of the installation for the permanent stable application. The default setting is "rP:oFF".

oc: 3.5 It is recommended for "oc" to set at the rating current of motor. Default setting is oc:5.0A .

dt: 5 It means a starting delay time setting for a motor start up duration from the start of motor to the normal running current. The start up duration depends on the inertia of load. Therefore, it is recommended to set the time after

measuring the time and current by EOCR with the initial set of D-time at 20 sec. For a Star-delta start, the longer time by 2sec than the setting of Star-delta timer is recommended. Default setting is 5 sec.

ot: 5 It means the overcurrent trip time in definite TCC, when motor operating current (In) exceeds over current setting (Is) during the ot setting time, EOCR trips. Default setting is 5 sec. The advantage of definite TCC is that user is able to set accurate time and current and lead a mechanical protection of load together with motor protection.

ctS: 5 This is a trip class(curve) setting in Inverse TCC or Thermal inverse TCC. The trip time changes according to the operating current inverse proportionally. Thermal inverse TCC reflects the Heat capacity of motor based on the current measurement.

uc:oFF It means under current (Dry Run) protection, If a level switch has a problem in a submersible pump, It backs up the level switch function from no water running of pump and protect the motor from overheating. For the machinery running with a belt (including conveyer), It candetect a broken belt. The current setting should be higher than rating no load current of motor for this function. The default setting is "oFF" .

ut: 5 It is "uc" trip delay time setting . If you don't set the "uc" function (uc:oFF), "ut" setting doesn't appear at the menu.

PL: on This menu is to determine "enable/disable" of PL (Phase loss) function. If you set "Ph:1Ph" at the power phase selection menu for a single phase power supply line, this menu doesn't appear automatically.

PLt: 3 It is trip delay time setting for PL. The default setting is 2 sec. For single phase power line setting, it doesn't appear at the menu.

Ub: 15 EOCR calculates the unbalance rate among three phase currents. It trips after "Ubt" setting time under a unbalanced condition. The default setting is "oFF".

Sc: 4 Locked Rotor protection during starting up a motor (Stall). If a rotor of motor is locked during starting and keep the current at higher than the "Sc" setting during D-time, EOCR trips in 0.5sec after D-time. The default setting is "Sc: 4".

The setting value is a multiple of "oc" setting value. This function operates under the Definite TCC condition. It is disabled under the Inverse TCC setting generally. But if you set D-time greater than zero in Inverse setting, Stall operates when d-time expires.

EOCR Setting Guide

EOCR Setting Guide

JR: 4 Locked rotor protection during normal running of motor (Jam). It is used to prevent a problem caused by rapid load increase. The setting value is a multiple of "oc" setting value. The trip delay time setting range is 0.2~10 sec.

RL: 85 Alarm setting by % of the overcurrent threshold (oc). The output contact 07-08 makes a signal of A,F,H according to the ALo setting.

rt:E-r Reset type setting mode. Reset method shows below.

rt:E-r Electrical Reset . EOCR resets by power cycle of control power or ESC button. It can be used for a remote reset which enables EOCR to reset from a remote site.

rt:H-r Hand Reset (Manual Reset). EOCR can be reset by ESC button only.

rt:R-r Auto Reset . The time setting range is up to 20 minutes (20n). The auto reset number. of times is connected to the restart limitation setting menu. If the number of restart over the restart limitation number. in the "rn" setting menu during 30 minutes, EOCR doesn't reset anymore.

rn: 3 Restart limitation number. It prevent a motor from a burning fail caused by many restarts during 30 minutes. In case an emergency restart is necessary, put the setting at "OFF" This function activates in Auto-Reset mode only.

Rd: 1 Modbus slave (ID) address. It can be set at No. 1 ~ 247.

bp: 192 Setting for communication speed. Select one among 1.2kbps, 2.4kbps, 4.8kbps, 9.6kbps, 19.2kbps, 38.4kbps.

Pr:Eun Parity setting. Select one among odd, even, non. even parity is displayed as "Eun".

Lt: 10 Communication loss checking menu. If EOCR does not receive a data frame during "Lt" setting time, it displays an error message. The setting range is OFF, 1~999 sec.

-trh- Total running hour. Time accumulation starts if there is a minimum sensing current in the line up to 99,999 hours. User can check it anytime but not allowed to erase it. Display unit is 1 hour.

-rh- Running hour which user can set and erase the setting value. If you set the Alert output type at the "ALo: to", the output contact 07-08 repeats close and open to give a signal after the preset accumulated time elapsed.

tEst Self EOCR Check. If you push SET button in this menu, EOCR count time up 3sec and "ot" setting time and displays "End" with the output contact trip. This means EOCR is operating well. This function is blocked during motor running.

Additional menu (i3MS/iFMS)

SH: 10 Short Circuit protection. Setting value is a multiple of "oc" set value.
Default setting is 10 times of "oc" setting.

SHd: 7 Short Circuit trip delay time during motor starting to prevent a trip caused by starting current. "OFF" setting is possible .

Additional Menu (i3MZ/iFMZ, 3MZZ/FMZ2)

Ec: 0.5 Earth leakage protection current setting. The default setting is 0.5A. Minimum setting value is recommended, if there is no leakage current in the motor by the current display. If the display shows a leakage current more than 50mA, user must check the insulation of motor and line. In the case of installing EOCR at the secondary side of Inverter, it's better to take care of EOCR operation error due to harmonics of Inverter.

Et:0.05 Earth leakage trip time. The default setting is "0.05sec". It is recommended to set the faster time and lower current than the earth fault protection relay in the upper power system.

Edt: 6 Earth leakage trip delay time during motor starting to prevent a trip caused by a stray current and harmonics of the starting current in motor.

Additional menu (i3M420/iFM420)

r5: 50 Current range setting menu of 4~20mA analog output signal. The setting value corresponds to the max analog output (20mA). The setting value can be made independently from "oc" setting .
Analog output current formula :

$$\text{mA} = \frac{I}{rS} \times 16 + 4$$

Where, CTR is the parameter for CT, i.e. in case of CI : non, it is 1. I is the measured average load current.

If the load current is equal or greater than this value, analog output is fixed to 20mA . For the current lower than minimum sensing current of EOCR(0.4A), the analog output signal gives 4 mA .

Troubleshooting Guide

Troubleshooting Guide

1. Reversed phase : `-rP-`

It trips instantly within 0.15sec from the motor starting. Check the phase sequence and cable direction of the power line going to the motor first. The sequence of EOCR internal CT is A(L1), B(L2), C(L3) from the left side. If the passing order of motor line to the EOCR doesn't coincide with the order of EOCR CT or not same all the direction of cables, It trips by RP. In this case, change the order of the two cables among three. When the sequence of cables to the motor changes in the downstream side of EOCR, EOCR isn't able to check the RP. The sequence of cables should be coincided from the power mains to the motor. If the RP is not an indispensable function or only necessary for the first installation and fixed in the site, The `rP:OFF` is recommended for normal operation.

2. Overcurrent : `oc: 35`

Overcurrent trip displays the biggest current among three phases and the small LED in the left side shows the phase. If the trip current is lower than the rating current of motor, check the "oc" setting if it is too low. The recommended "oc" setting is 110%~120% of actual running current in the definite TCC.

3. Stall : `Sc: 35.0`

When the starting current doesn't go down below the "Sc" setting during D-time. EOCR trips by Stall within 0.5se when D-time expires. Check the status of load and D-time, whether the D-time is too short or not. The recommended D-time is longer by 1sec than a time that the motor come to the normal running current.

4. Phase loss : `PL - r` `PL - S` `PL - t`

The small LED in the left side lights up and designates which phase is lost in the display like as PL - r, PL - S, PL - t, To check the PL status, put the PL trip time at the maximum and measure the lost phase current by a clamp meter after a test start, whether there is a current in the motor line or not. The minimum operating current (min setting current) of motor sensed by EOCR can make trip due to hunting current. Need to check load operation condition of the application in this case. If the clamp meter shows a normal current in the lost phase line, Check the EOCR status.

5. Unable to starting :

Even though the sequence wiring is O.K. If the motor is not able to be started with no magnetic contactor energized, Check the Fail Safe menu of `F5: ON` `F5:OFF` with the output contact status (NO, NC) of EOCR.

6. Undercurrent : `uc: 1.5`

Undercurrent trip displays the lowest current among three phases and the small LED in the left side shows the phase. The example shows the sensing current of 1.6A in L2(S) phase. For the heater line broken detection in a heater application. EOCR trips by undercurrent according to the setting in delta connection, and trips by phase loss in Star connection.

7. Current unbalance : `ub: 42`

Ideally, the motor currents of three phases are balanced. If a current unbalance is high, the motor need to be checked.

The formula is as follows.

$$\text{Unbalance factor (\%)} = (\text{Imax_phase} - \text{Imin_phase}) / \text{Imax_phase} \times 100\%$$

8. Jam : `JR: 15.8`

Rapid overload protection during motor running, Check the load which cause impacts it. If you find no problem in the load and motor, try to change the setting value higher of the time and current to be appropriate for the application.

9. Unable to reset : `rt:H-r`

If you cannot reset EOCR by control power interruption, Check the reset type setting first. In the setting of `rt:H-r` User can reset EOCR by ECS button only. If you want to reset EOCR by both control power cycle and ECS button, Put the setting at `rt:E-r`

Communication Guide

Modbus network setting

Communication setting value

Please set the Modbus communication parameters by PCON or HMI for the communication.

- Slave address
- Baud rate
- Parity
- Communication loss timeout

Slave address

The EOCR has slave addresses from 1 to 247.

The factory default setting is 1.

Baud rate

The Communication speed provided is like below.

- 1.2kbps
- 2.4kbps
- 4.8kbps
- 9.6kbps
- 19.2kbps
- 38.4kbps

The factory default setting is 19.2kbps

Parity setting

- Even
- Odd
- None

The factory default setting is even. Please refer to the table for the stop bit setting.

Parity setting	Stop bit
Even or Odd	1
None	2

Communication loss timeout

It is the criteria to confirm the communication disconnection with a master like as PLC.

EOCR judges it as a communication disconnection error, if there is no call from the master during a certain preset time.

The time setting range is 1~999sec the factory default setting is OFF. The OFF means no communication error check. It is advised to set it at OFF, if there is no concern of communication disconnection or no needs of communication error check at ordinary times.

RS485 bus connection

RS485 standard allows several different characteristics.

- Polarization
- Line terminator
- Number of slaves
- Length of the bus

There is a definition of Modbus presented in detail at the website of Modbus.org in 2002.

Standard connection

Communication Guide

Standard connection

The standard connection conforms to the Modbus specifications, sepecially 2 wire multidrop serial bus diagram, presented at the website of Modbus.org in 2002 (Modbus_over_serial_line_V1.pdf, Nov.2002). Simple wiring diagram is like below.

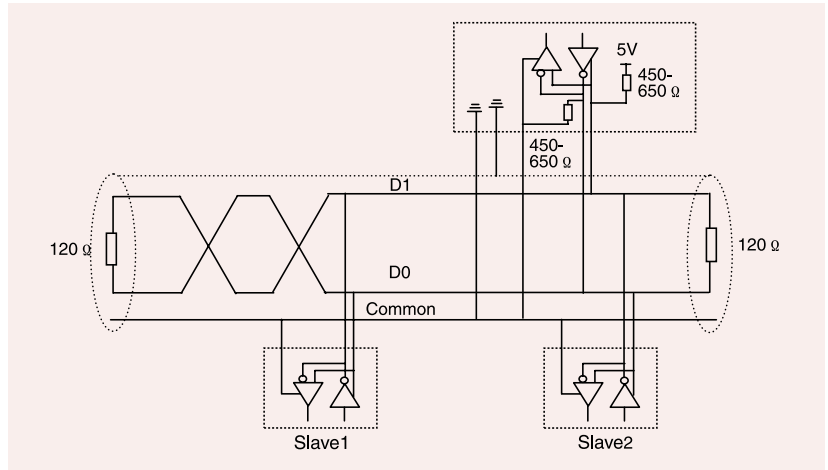

The characteristics is like below in case of a direct connection to the bus.

Items	Contents
Type of trunk cable	single, shielded, twisted pair cable. Min 3rd cable
Maximum length of the bus	1000m (3,2181 ft) (at 19.2kbps)
Maximum number of stations without repeater	32 stations (31 slaves)
Maximum length of tapoffs	<ul style="list-style-type: none"> • 20m (66ft, at 1 tapoff) • 40m (131ft, divided by tapoff no. in Multi-Junction Box)
Bus polarization	<ul style="list-style-type: none"> • 450 - 650Ω Pullup resistor, 5V basis • 450 - 650Ω Pulldown resistor, Recommend the polarization to Master at Common. There is no polarization at RS485 of EOCR .
Line terminator	120Ω Resistor, + /- 5%
Common polarity	YES (connect 1 protection ground minimum to the bus)

Communication Guide

Bus connection through a SCA type junction box

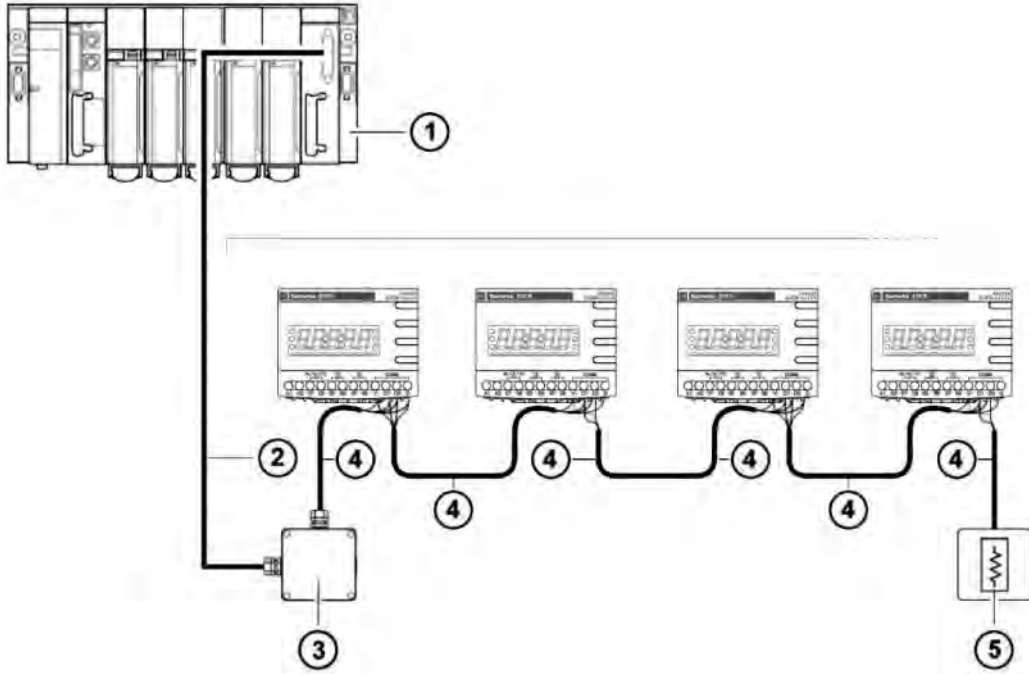

1. Master (PLC, PC or communication module)
2. Modbus cable (It is different according to the master side or a master having polarization combined to the other part of Bus)
3. Junction box
4. Modbus cable
5. Line terminators : 120Ω - 0.25W

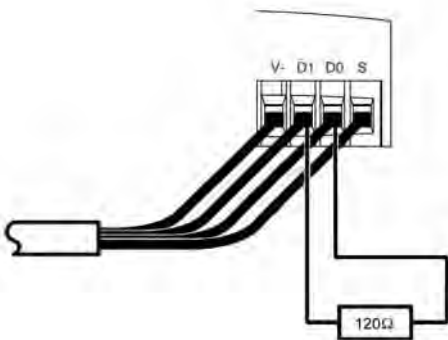

Please use a cable with 2pair shielded twisted conductors for Interface protection.
It is advised to isolate the Modbus cable 30cm(11.8in) at least from a power cable.
If necessary, intersect the Modbus cable to a power cable perpendicularly.
Refer to the diagram in the left side for the line terminator wiring.